



# HYDRANTS

## NON-FREEZE GROUND HYDRANT

### BOX TYPE WITH INTEGRAL FLASHING FLANGE AND CLAMP

**FUNCTION:** A Hydrant with a hinged covered box, for positive protection against freezing when buried outside or in unheated areas and the closing valve is located below the frost line. Used in watertight floor construction where an integrally cast flashing flange is required to receive and secure the waterproofing membranes. When hydrant is shut off water is drained from the casing through the drain hole in the valve housing. The locking cover prevents unauthorized use.

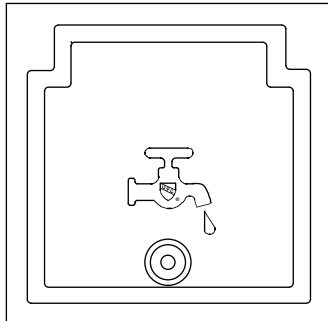

B(Depth of Bury) = 02(610), 03(915), 04(1220), 05(1525), 06(1830), 07(2135) or 08(2438) Feet  
 \*B = 9 1/2"(240) When Specified 3810F-SAP  
 \*B = 9 1/2"(240) When Specified 3811F-SAP



**NOTES:** 1. Recommended Box-out 10-1/2"(265) x 10-1/2"(265)  
 2. All hydrants are manufactured with "NO-LEAD" brazing rings and USDA approved lubricants.

**NOTE:** Addition of vacuum breaker will not allow draining of the casing. Smith is not responsible for any casings that burst or related incidents if the hydrant is supplied with a vacuum breaker.



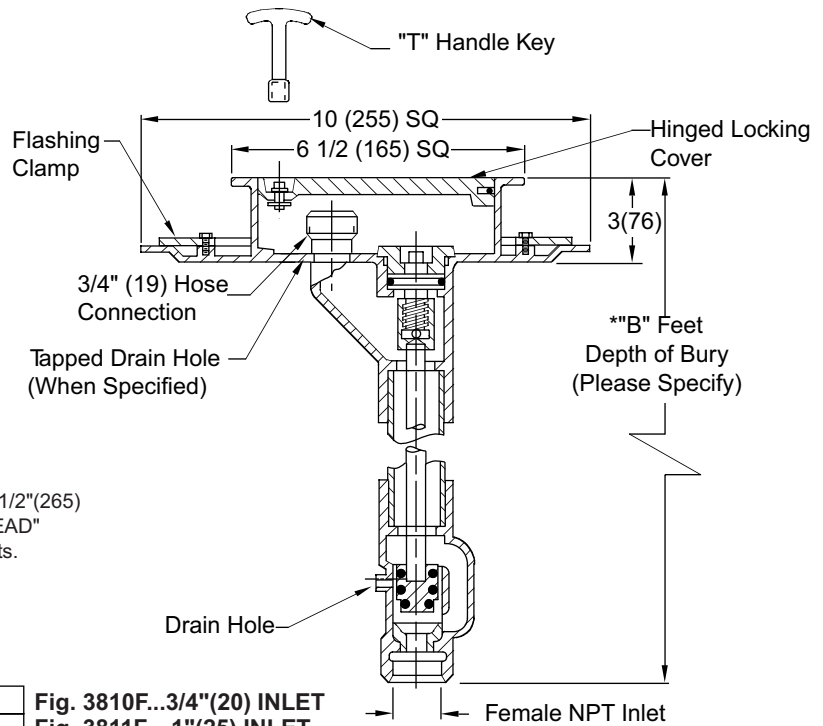



#### REGULARLY FURNISHED:

Bronze Non-Freeze Ground Hydrant with "T" Handle Key, Bronze Hydrant Box with Flashing Flange and Clamp. Inlet Size Furnished as Indicated by Figure Number Selected.





 Fig. 3810F... 3/4"(20) INLET  
 Fig. 3811F... 1"(25) INLET

#### VARIATIONS:

-  1"(25) Hose Connection Adapter -HC1
-  Less Drain Hole -LD
-  1/8"(3) NPT Drain Hole in Box -N
-  1/8"(3) NPT Drain Hole in Valve Housing -NV
-  Mild Climate -SAP
-  Less Flashing Clamp -LFC
-  "Water" Cast on Cover -W

#### OPTIONAL MATERIALS:

-  Nickel Bronze Box -NB
-  Polished Bronze Box -PB

**NOTE:** Dimensions shown in parentheses are in millimeters.

### TECHNICAL DATA

Non-Freeze Ground Hydrants are supplied with a special valve housing which prevents freezing of hydrant during non-use periods. The valve housing must be installed below the frost line which prevails for the area of installation. The valve housing has a drain hole which drains the casing when the hydrant is shut off. In effect, there is no water in the casing during non-use periods. Since water from the drain hole is normally allowed to drain into the ground, the valve housing should be set in a bed of gravel. Water drained from the casing can then seep into the ground.

Some locations which require Non-Freeze Ground Hydrants cannot tolerate water draining from the drain hole. Examples are parking garages, plazas and roof decks used for recreational purposes. Often in these types of applications the valve housing will protrude into a finished area which is not subject to freezing temperatures. To eliminate the problem of water drainage in this type of installation, Smith can supply a tapped drain hole in the hydrant box and a tapped drain hole in the valve housing. Through these tapped drain holes, water accumulation in the box and the water from the valve housing drain hole can be piped to a suitable drain.

 **WARNING:** Cancer and Reproductive Harm - [www.P65Warnings.ca.gov](http://www.P65Warnings.ca.gov)



# HYDRANTS

## Hydrant Part List

NON-FREEZE  
GROUND HYDRANT

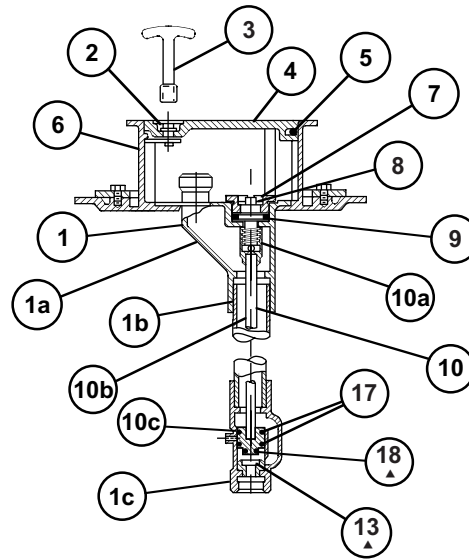
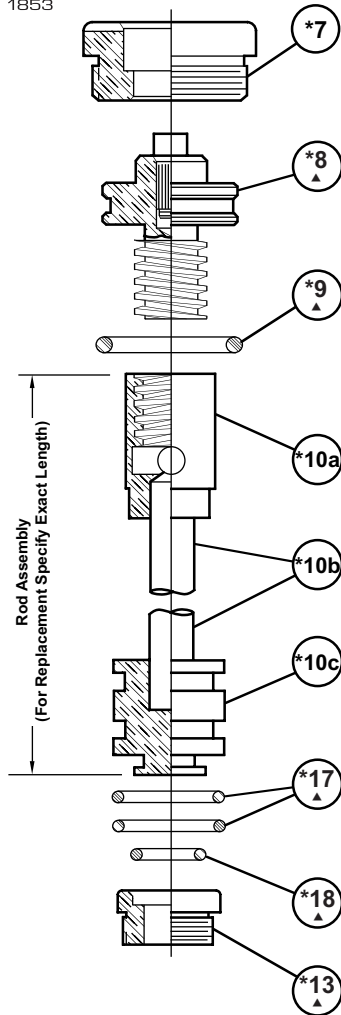

▲ THESE REPLACEMENT PARTS AVAILABLE IN HPRK-41

### MAINTENANCE INSTRUCTIONS

1. Shut off water supply.
2. Remove face nut.
3. Pull stem out for complete access to all working parts.
4. Check all working parts for replacement.
5. Replace complete stem assembly and face nut.

\*These parts are accessible from face of hydrant by removing face nut.

REPLACEMENT PARTS LIST - SPECIFY FIGURE NO. WHEN ORDERING			
No.	DESCRIPTION	No.	DESCRIPTION
1	Head/Casing Assembly	8	Operating Screw
1a	Head	9	Operating Screw "O" Ring
1b	Casing	10	Operating Rod Assembly
1c	Valve Housing	10a	Coupling
2	Locking Device	10b	Rod
3	Key	10c	Plunger
4	Cover	13	Removable Seat
5	Hydrant Cover Hinge Pins (2)	17	Plunger "O" Ring
6	Box	18	Plunger "O" Ring
7	Face Nut		

Murdock Mfg.™ warrants that its products are free from defects in material or workmanship under normal use and service for a period of one year from date of shipment. Murdock's liability under this warranty shall be discharged solely by replacement or repair of defective material, provided Murdock™ is notified in writing within one year from date of shipment, F.O.B. Industry, California.

SELECTION SUMMARY & APPROVAL FOR MANUFACTURING

Model Number & Options \_\_\_\_\_ Quantity \_\_\_\_\_

Company \_\_\_\_\_

Contact \_\_\_\_\_ Title \_\_\_\_\_

Signature \_\_\_\_\_ Date \_\_\_\_\_  
(Approval for Manufacturing)

All dimensions are subject to manufactures tolerance of plus or minus 1/2" nominal and subject to change without notice. Murdock assumes no responsibility for use of void or superseded data. Dimensions may change with the addition of optional accessories. Murdock Mfg.™, Member of Morris Group International™. Please visit [www.murdockmfg.com](http://www.murdockmfg.com) for most current specifications.