

**INSTALLATION INSTRUCTIONS:**

- A- REFERENCE DRAWING # 9938-340-0M1 FOR INSTALLATION OF -FRU1 UNDERGROUND FREEZE RESISTANT VALVE ASSEMBLY.
- B- PROVIDE 30" SQUARE MINIMUM x 6" DEEP MINIMUM CONCRETE SLAB BY OTHERS TO SECURELY ANCHOR FIXTURE. INSTALL THE FOUR PROVIDED CONCRETE ANCHORS (1) AT DIMENSIONS SHOWN TO MATCH HOLES (2) IN FIXTURE BASE.
- C- PROVIDE FOR BUTTON AND WATER SUPPLY TUBING ENTRY INTO BOTTOM OF FIXTURE THRU 6" DIAMETER OPENING.
- D- ROUGH-IN WASTE OUTLET (3) CENTERED AS SHOWN FOR 1-1/4" PVC PIPE SIZE OR USE THE COMPRESSION ADAPTER PROVIDED LOOSE FOR 1-1/4" OUTER DIAMETER TUBE.
- E- CAREFULLY REMOVE FIXTURE (4) AND COMPONENTS FROM THE PACKAGING PREVENTING SCRATCHING AND DAMAGE.

- F- REMOVE BACK ACCESS PANEL (5) FROM FIXTURE PEDESTAL (4) AND BOTTOM ACCESS PANEL (6) FROM CANTILEVER (7). ENSURE PUSHBUTTON (8), WASTE PIPING (9), AND BUBBLER (10) ARE SECURE AND CHECK ALL THE TUBING CONNECTIONS TO MAKE SURE THEY DID NOT COME LOOSE IN SHIPMENT.
- G- SET PEDESTAL (4) IN PLACE ALIGNING BASE HOLES (2) WITH THE INSTALLED ANCHORS (1) AND SECURE WITH THE 1/2" UNC HARDWARE (11) PROVIDED.
- H- MAKE-UP WASTE CONNECTION TO THE WASTE PIPING (9).
- I- RUN TUBING FROM FIXTURE TO FREEZE RESISTANT VALVE AND COMPLETE INSTALLATION FOLLOWING DWG # 9938-340-001.
- J- TEST OPERATION OF BUBBLER BY DEPRESSING BUTTON (8). CHECK ALL CONNECTIONS AND WASTE PIPING FOR LEAKS. CORRECT IF PRESENT.
- K- RE-INSTALL BACK ACCESS PANEL (5) AND BOTTOM ACCESS PANEL (6).

 <p>MURDOCK-SUPER SECUR P.O. Box 3527 Industry, CA 91744 15125 Proctor Ave Industry, CA 91746 Phone: (800) 591-9880 www.murdock-supersecur.com</p>	<p>TITLE <b>GRJ85-FRU1 FREEZE RESISTANT ROUND OUTDOOR ADA DRINKING FOUNTAIN</b></p>		
	<p>MANUFACTURE DATE</p> <p><b>JANUARY 2006</b></p> <p><b>TO PRESENT</b></p>	<p>DATE ISSUED</p> <p><b>09/27/05</b></p> <p>DATE REVISED</p> <p><b>01/12/21</b></p>	<p>DRAWING NUMBER</p> <p><b>9938-112-001</b></p>

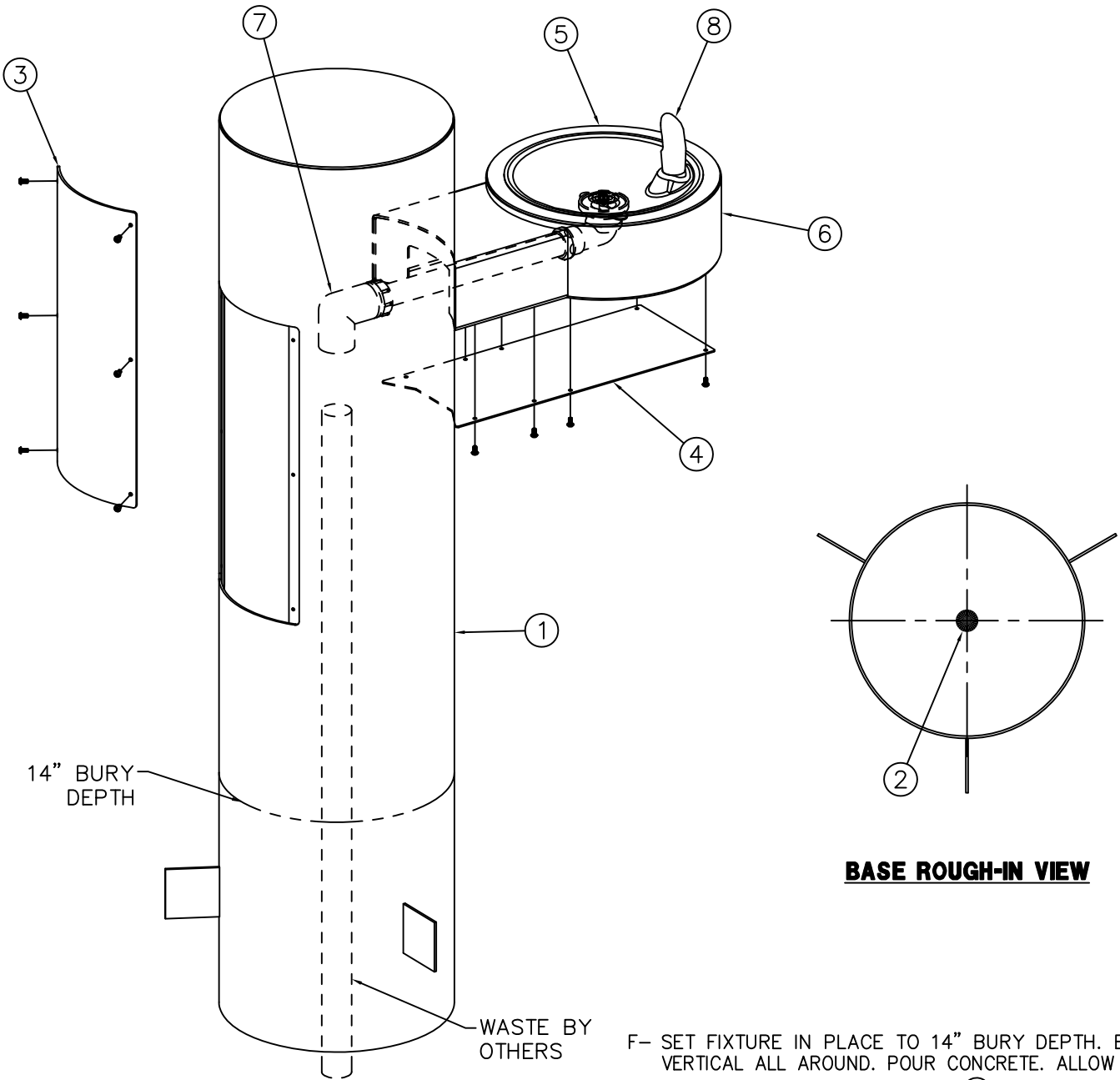

**INSTALLATION INSTRUCTIONS:**

- A- REFERENCE DRAWING # 9938-340-0M1 FOR INSTALLATION OF -FRU1 UNDERGROUND FREEZE RESISTANT VALVE ASSEMBLY.
- B- PREPARE INSTALLATION LOCATION TO BURY FIXTURE PEDESTAL ① TO 14" DEPTH.
- C- PROVIDE FOR BUTTON AND WATER SUPPLY TUBING ENTRY INTO BOTTOM OF FIXTURE.
- D- ROUGH-IN WASTE OUTLET ② CENTERED AS SHOWN FOR 1-1/4" PVC PIPE SIZE OR USE THE COMPRESSION ADAPTER PROVIDED LOOSE FOR 1-1/4" OUTER DIAMETER TUBE.
- E- CAREFULLY REMOVE THE FIXTURE AND COMPONENTS FROM THE PACKAGING PREVENTING SCRATCHING AND DAMAGE.

- F- SET FIXTURE IN PLACE TO 14" BURY DEPTH. ENSURE IT IS VERTICAL ALL AROUND. POUR CONCRETE. ALLOW TO CURE.
- G- REMOVE BACK ACCESS PANEL ③ FROM FIXTURE PEDESTAL ① AND BOTTOM ACCESS PANEL ④ FROM CANTILEVER ⑤. ENSURE PUSHBUTTON ⑥, WASTE PIPING ⑦, AND BUBBLER ⑧ ARE SECURE AND CHECK ALL THE TUBING CONNECTIONS TO MAKE SURE THEY DID NOT COME LOOSE IN SHIPMENT.
- H- MAKE-UP WASTE CONNECTION TO THE WASTE PIPING ⑦.
- I- RUN TUBING FROM FIXTURE TO FREEZE RESISTANT VALVE AND COMPLETE INSTALLATION FOLLOWING DWG # 9938-340-001.
- J- TEST OPERATION OF BUBBLER BY DEPRESSING BUTTON ⑥. CHECK ALL CONNECTIONS AND WASTE PIPING FOR LEAKS. CORRECT IF PRESENT.
- K- RE-INSTALL BACK ACCESS PANEL ③ AND BOTTOM ACCESS PANEL ④.



MURDOCK-SUPER SECUR  
P.O. Box 3527 Industry, CA 91744  
15125 Proctor Ave Industry, CA 91746  
Phone: (800) 591-9880  
www.murdock-supersecur.com

TITLE <b>-FRU1 FREEZE RESISTANT -IGM IN-GROUND MOUNTING ROUND ADA FOUNTAIN</b>		
MANUFACTURE DATE <b>JANUARY 2006 TO PRESENT</b>	DATE ISSUED <b>09/27/05</b>	DRAWING NUMBER <b>9938-113-001</b>
	DATE REVISED <b>03/15/16</b>	



# -FRU FREEZE RESISTANT VALVE SYSTEM

INSTALLATION/MAINTENANCE INSTRUCTIONS

## INSTALLATION INSTRUCTIONS FOR -FRU OPTION

Important: Read all instructions and refer to local codes prior to installation.

Prepare trench for water supply line and waste line (if required) a minimum of 21" below frost line. At fountain location prepare hole to trench depth and large enough for a person to work. Provide 36" centerline of PVC Pipe Casing & FRU valve to fixture location. Lay supply and waste into trench allowing extra length to be trimmed during hook-up.

Depending on code and design requirements, drain may be open, French or sanitary connection. Under drain and PVC Tube Casing opening, place a minimum of five cubic

feet of porous gravel fill. Local soil conditions may require more gravel for drainage.

- It is recommended to include a supply stop appropriately located on the supply line.
- An in-line PRV installed on the supply line is recommended to ensure a working water pressure of 40-60 psi.
- A water filter should be installed on the supply line if sediment or mineral content is a problem.
- A 1/2" NPT swivel elbow supply fitting below PVC Pipe Casing will assist in making up connections to the FRU valve inlet hose.

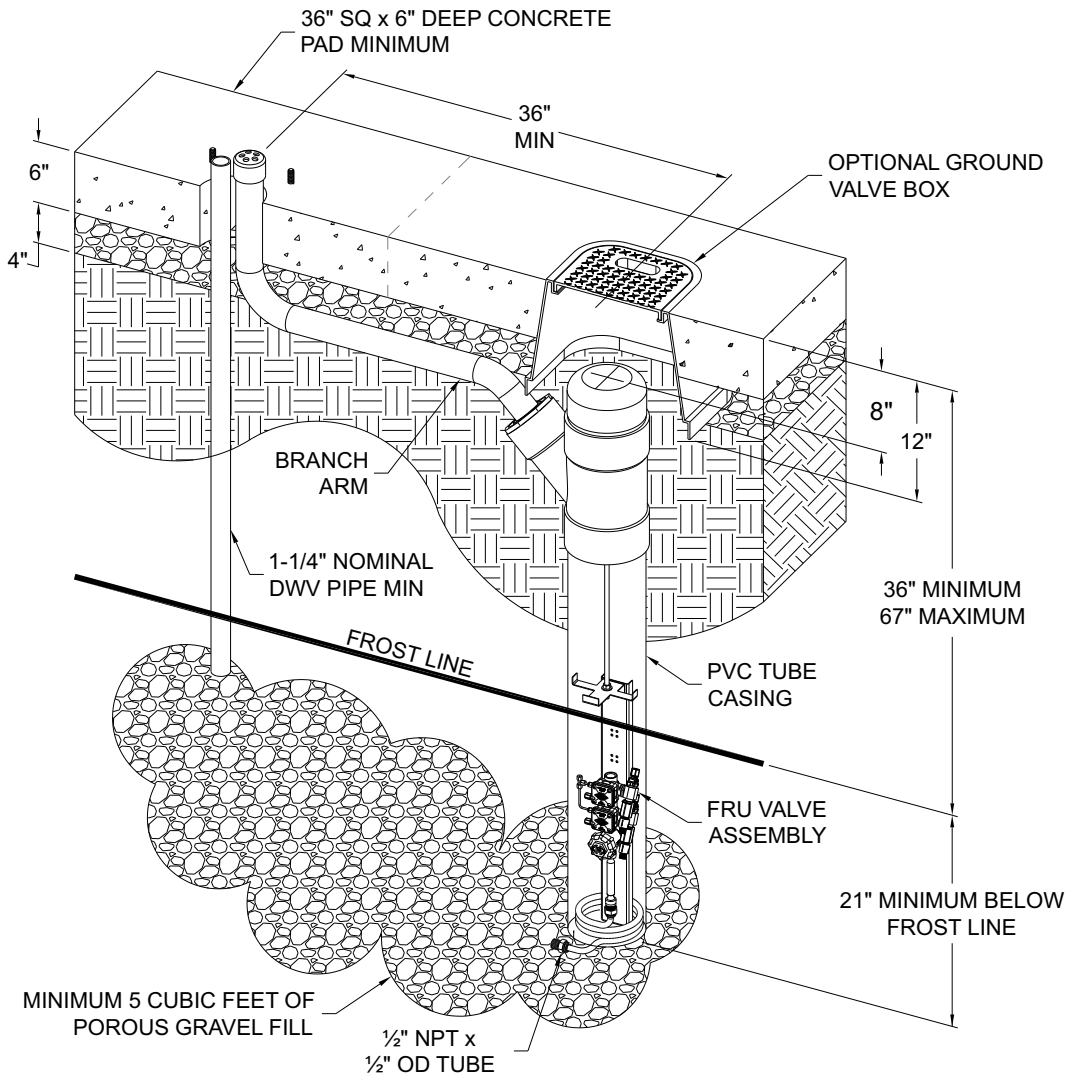

**Valve Specifications:**  
 Minimum/Maximum Pressure:  
 30/100 PSI

Please visit [www.murdock.com](http://www.murdock.com) for most current specifications.



# -FRU FREEZE RESISTANT VALVE SYSTEM

## INSTALLATION/MAINTENANCE INSTRUCTIONS

Assemble PVC Tube Casing following manufacturer's instructions for primer and glue by others. Do not glue caps. Trim bottom excess of PVC Tube Casing and FRU all-thread lowering rod to allow FRU valve assembly to be lowered a minimum of 21" below frost line. Make up supply connection to loose fixture flexible hose inlet and test for leaks. Pull hose through assembled PVC Tube Casing and connect to FRU.

Position assembled PVC Tube Casing as indicated with Branch Arm orientated toward fixture. Install optional Ground Valve box as required. Refill trench and hole, compacting back fill as required. Leave sufficient depth in hole to accommodate concrete pad (by others).

Prepare the slab area surrounding fountain spreading and compacting gravel as necessary. Prepare forms (refer to fixture installation) to protect Branch Arm and waste stub outs. If required, fix 1/2" UNC L-bolt anchors by others in position arranging L-bolts according to pattern indicated and pour concrete to grade. Leave enough thread for mounting base. Ensure concrete top surface is flat and level. If concrete has cured use appropriate 1/2" concrete anchoring hardware by others following the manufacturer's installation recommendations.

Allow concrete to cure before completing installation.

Position fixture near installation site and thread 1/8" OD Breather tube from FRU valve through Branch Arm, Branch Arm Cap and fixture pedestal and fix to pedestal interior with duct tape by others.

Thread 1/4" OD riser(s) and pushbutton 1/8" OD tubing thru Branch Arm Cap and Branch Arm to make up connections to FRU valve.

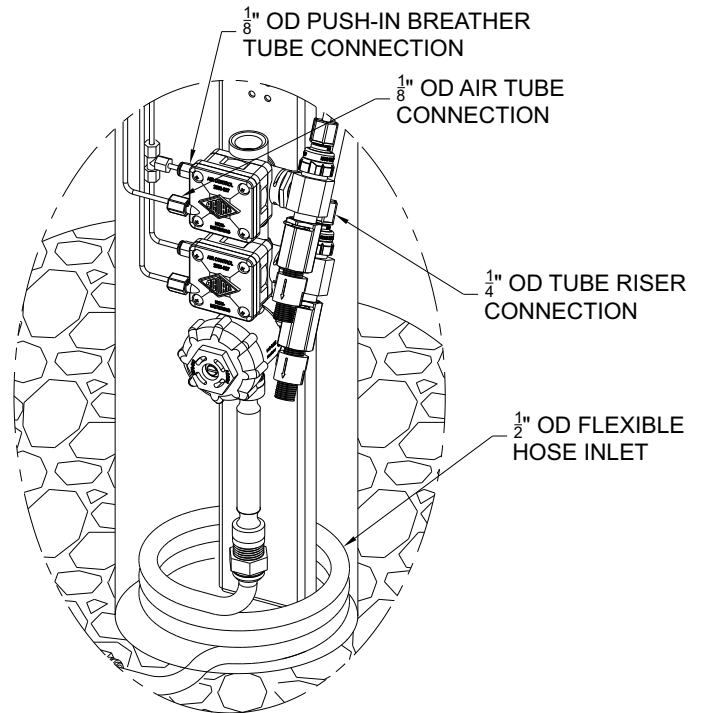

Set fixture into position aligning anchoring studs to pedestal mounting holes. Secure pedestal to slab. After securing fixture in place, make up connections to fixture waste outlet. Refer to fixture installation sheet for additional information.

To ensure plumb installation, lay a bubble level on fountain bowl and adjust using shims or washers until unit is level.

Lower FRU valve assembly into PVC Pipe Casing coiling flexible hose within casing without kinking and seal with cap provided. Conceal and cover with ground valve box lid.

Turn on water supply and test for proper operation and checking for leaks. Ensure water drains out of risers at FRU and into gravel fill when flow stops.

**FYI:** Protect exposed valve assembly, tubing and tube openings to prevent damage to equipment or to prevent tubes from becoming filled with soil or debris.

Excess tubing should be trimmed to fit. When tubing is properly trimmed, FRU valve may be raised to grade level to allow maintenance or servicing and returned to bottom of casing when completed. Riser tubing should include no low spots where water may collect and freeze.

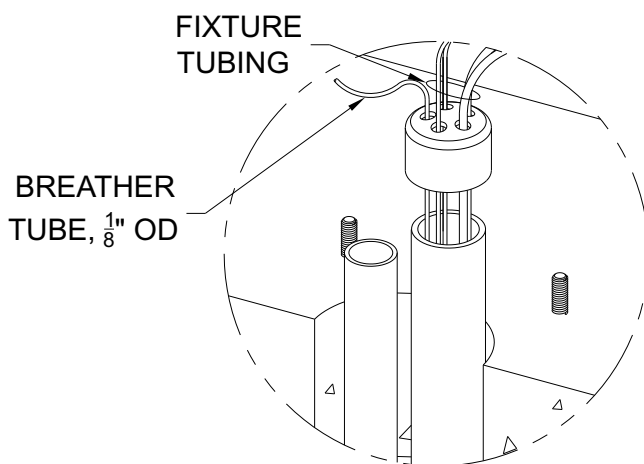

Please visit [www.murdock.com](http://www.murdock.com) for most current specifications.



# -FRU FREEZE RESISTANT VALVE SYSTEM

INSTALLATION/MAINTENANCE INSTRUCTIONS

Place insulation material by others in valve casing as shown and replace cap. Place insulation material by others in valve ground box and cover. Install drinking fountain access panels to complete installation.

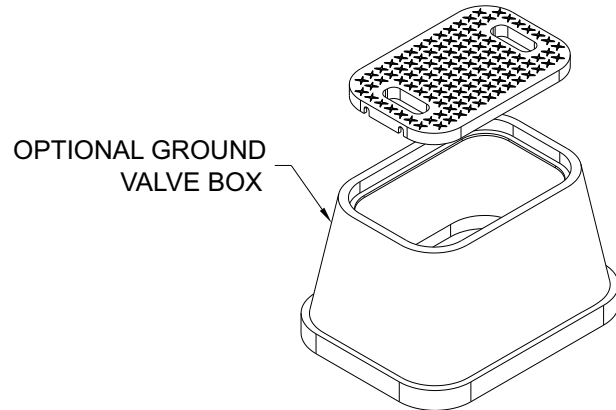
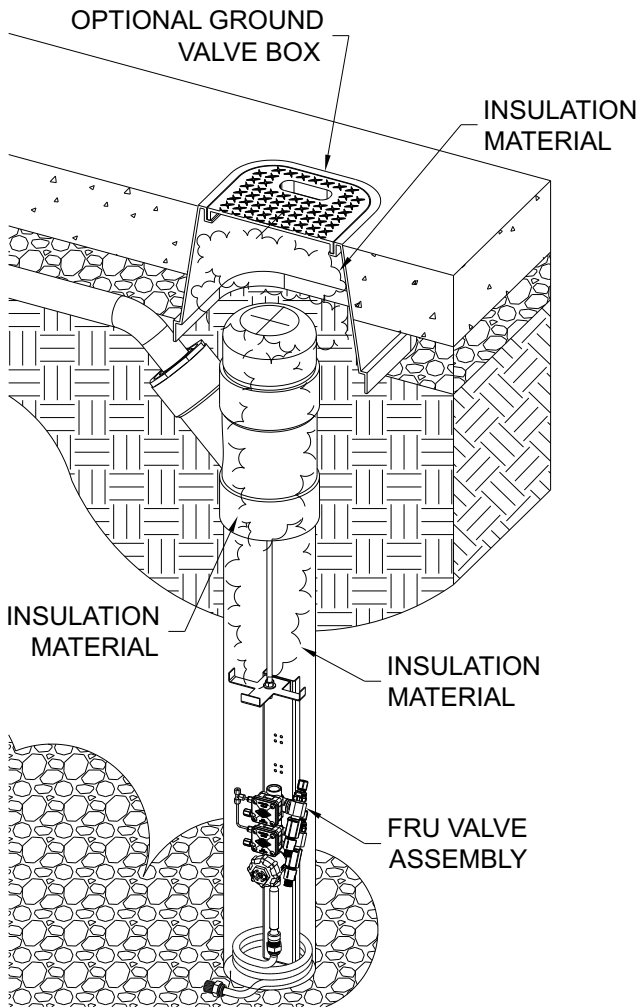
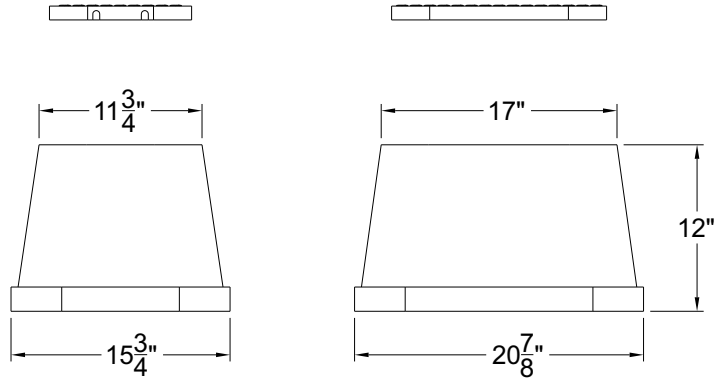

Please visit [www.murdock.com](http://www.murdock.com) for most current specifications.



# -FRU FREEZE RESISTANT VALVE SYSTEM

COMPONENTS AND REPAIR PARTS

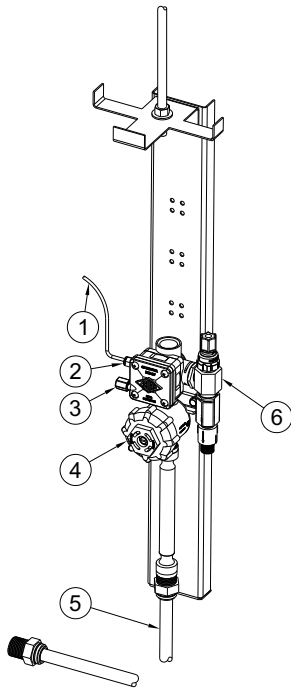

**FRU1**

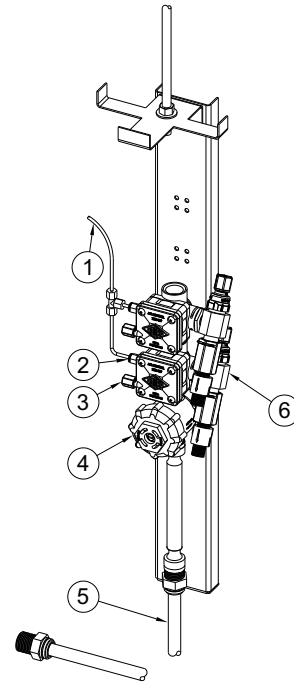

**FRU2**

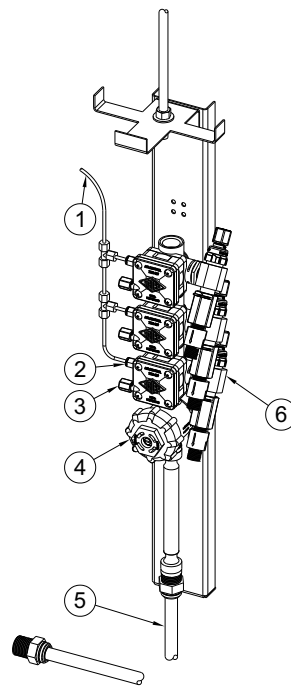

**FRU3**

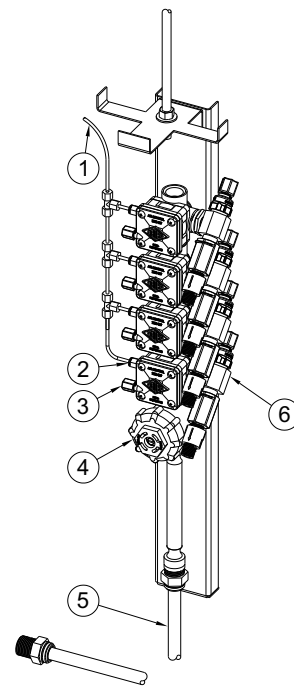

**FRU4**

- ① 1/8" OD BREATHER TUBE
- ② 1/8" OD PUSH-IN FITTING FOR BREATER TUBE
- ③ 1/8" OD COMPRESSION FOR PUSHBUTTON
- ④ VALVE CHECKSTOP
- ⑤ 1/2" OD x 10 FEET LONG REINFORCED HOSE INLET w/ 1/2" OD x 1/2" NPT FITTING
- ⑥ 1/4" OD COMPRESSION RISER FITTING

Please visit [www.murdock.com](http://www.murdock.com) for most current specifications.



# -FRU FREEZE RESISTANT VALVE SYSTEM

COMPONENTS AND REPAIR PARTS

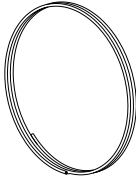
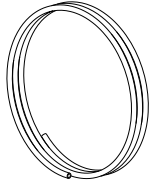
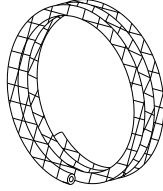
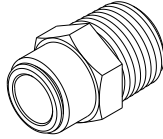
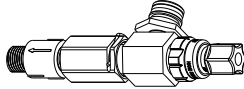
Description	Part No.	Diagram
<b>VALVE COMPONENTS</b>		
1/8" OD x 15 Feet Long, Polyethylene Tubing	2150-000-000	
1/4" OD (.040 Wall) x 15 Feet Long, Polyethylene Riser Tubing	2160-000-000	
1/2" OD x 10 Feet Long, Braided Reinforced Supply Inlet	7000-139-199	
1/2" OD x 1/2" NPT Push-in Fitting	7000-140-000	
Riser Check Valve Assembly	7000-115-003	
1/8" OD Tube TEE fitting	1895-400-000	

Please visit [www.murdock.com](http://www.murdock.com)  
for most current specifications.

**MURDOCK MFG.** • 15125 Proctor Avenue • City of Industry, CA 91746 USA  
Phone 800-453-7465 or 626-333-2543 • Fax 626-855-4860 • [www.murdockmfg.com](http://www.murdockmfg.com)

Member of  **MORRIS GROUP**  
INTERNATIONAL



# -FRU FREEZE RESISTANT VALVE SYSTEM

COMPONENTS AND REPAIR PARTS

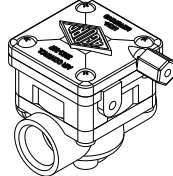
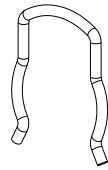
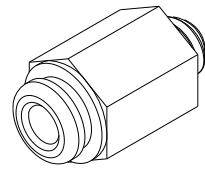
Description	Part No.	Diagram
VALVE COMPONENTS		
Direct Acting Valve Assembly -Open End	2570-100-001	
Retaining Clip, Air-Control Valves	0326-100-000	
1/8" OD x #10-32 UNFE, Push-In Fitting	7000-125-000	

Please visit [www.murdock.com](http://www.murdock.com)  
for most current specifications.

**MURDOCK MFG.** • 15125 Proctor Avenue • City of Industry, CA 91746 USA  
Phone 800-453-7465 or 626-333-2543 • Fax 626-855-4860 • [www.murdockmfg.com](http://www.murdockmfg.com)

Member of  MORRIS GROUP  
INTERNATIONAL



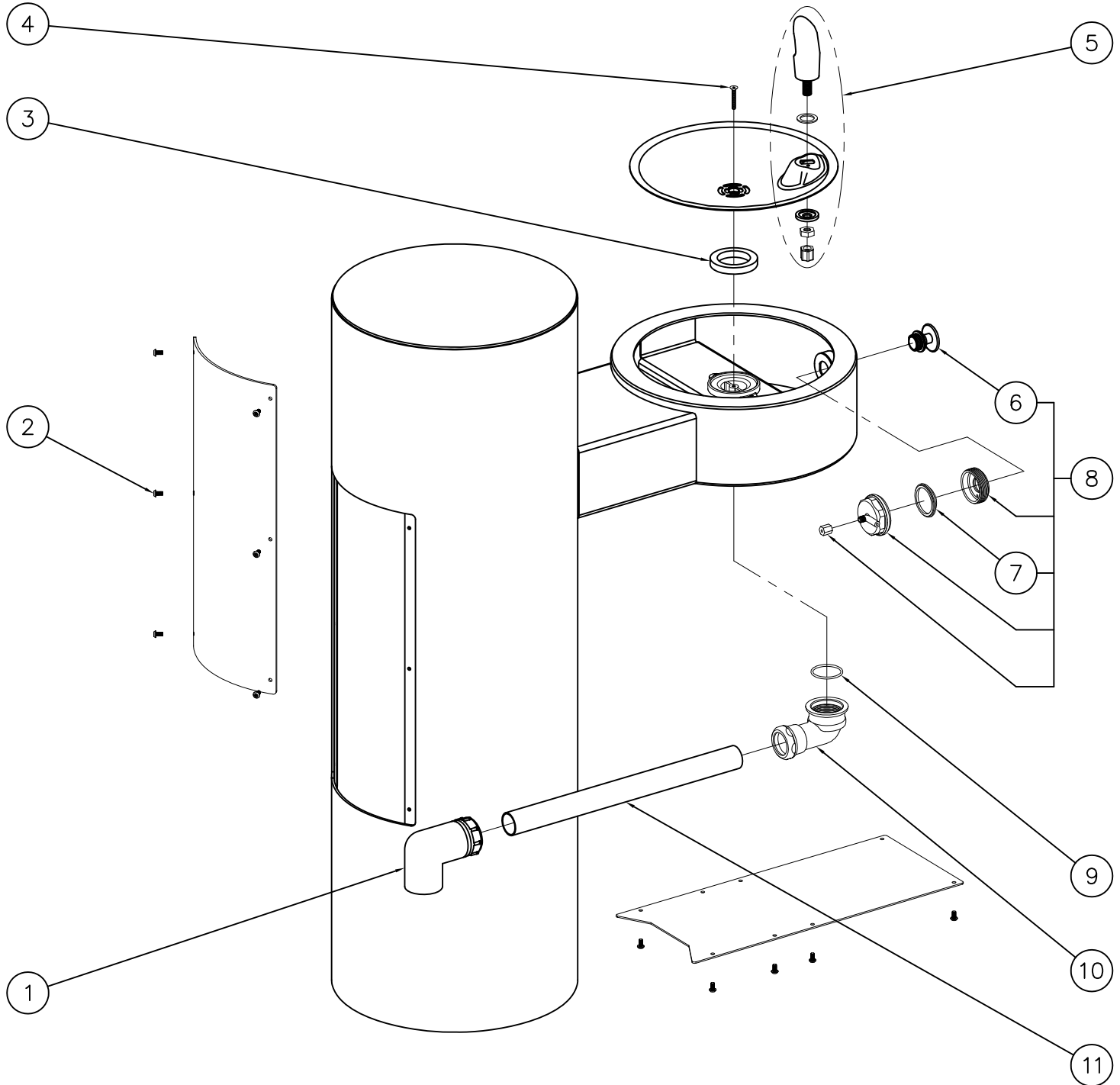

1	7002-013-001	1-1/4" O.D. ELBOW / COMPRESSION ASSY	7	2566-001-000	DIAPHRAGM
2	0112-001-000	CENTER REJECT ALLEN BUTTON HD SCREW	8	7002-125-001	PUSH BUTTON ASSEMBLY - OUTDOOR STEEL
3	7000-006-000	FLAT DRAIN ADAPTER GASKET	9	0401-128-000	O-RING
4	0152-010-000	CENTER REJECT ALLEN FLAT HEAD SCREW	10	7000-017-001	ELBOW ASSEMBLY
5	7000-012-001	STAINLESS STEEL BUBBLER	11	7000-111-199	1-1/4" O.D. x 14" LONG DRAIN TUBE
6	7002-125-002	PUSH BUTTON CAP ASSEMBLY			

ITEM	PART NUMBER	DESCRIPTION	ITEM	PART NUMBER	DESCRIPTION
MURDOCK-SUPER SECUR P.O. Box 3527 Industry, CA 91744 15125 Proctor Ave Industry, CA 91746 Phone: (800) 591-9880 www.murdock-supersecur.com		<b>TITLE -FRU1 FREEZE RESISTANT ROUND OUTDOOR STEEL ADA FOUNTAIN</b>			
		<b>MANUFACTURE DATE</b> JANUARY 2006 TO PRESENT	<b>DATE ISSUED</b> 01/19/06 <b>DATE REVISED</b> 03/16/16	<b>DRAWING NUMBER</b> 9938-112-500	

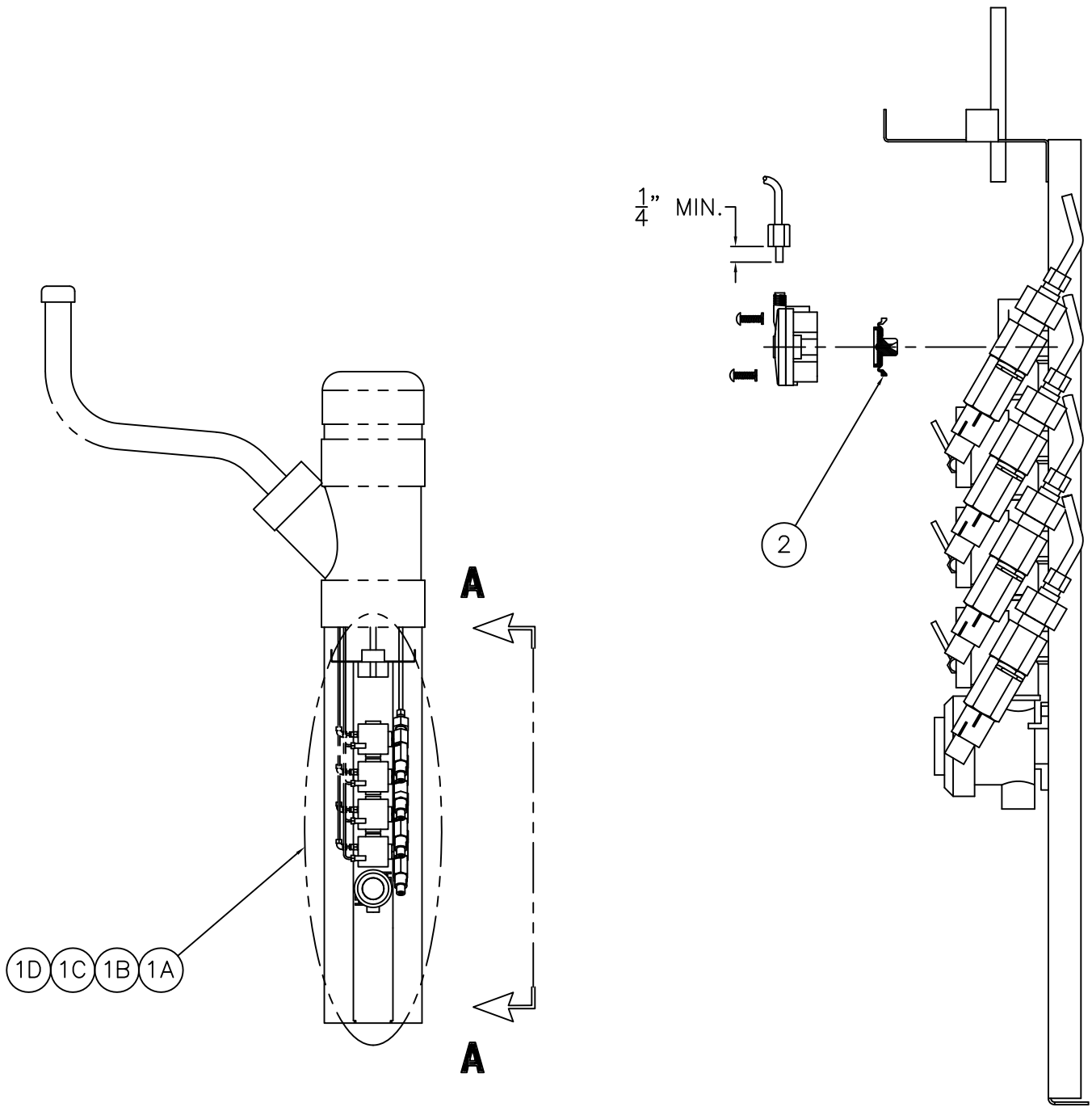

**VIEW A-A**

1A	7000-115-002	4-STATION FREEZE-RESISTANT VALVE ASSY	1D	7000-132-002	1-STATION FREEZE-RESISTANT VALVE ASSY
1B	7000-130-002	3-STATION FREEZE-RESISTANT VALVE ASSY	2	2563-010-001	WATER DIAPHRAGM ASSEMBLY
1C	7000-131-002	2-STATION FREEZE-RESISTANT VALVE ASSY			
ITEM	PART NUMBER	DESCRIPTION	ITEM	PART NUMBER	DESCRIPTION



MURDOCK-SUPER SECUR  
P.O. Box 3527 Industry, CA 91744  
15125 Proctor Ave Industry, CA 91746  
Phone: (800) 591-9880  
www.murdock-supersecur.com







<b>OPTIONAL -FRU FREEZE RESISTANT VALVE ASSEMBLIES</b>		
<b>MANUFACTURE DATE</b> <b>JANUARY 2006</b> <b>TO PRESENT</b>	<b>DATE ISSUED</b> <b>11/11/05</b> <b>DATE REVISED</b> <b>03/15/16</b>	<b>DRAWING NUMBER</b> <b>9938-340-500</b>

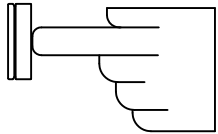

**PUSH PAD / PUSH BUTTON FRU FREEZE RESISTANT DRINKING FOUNTAINS  
NON-METERING AIR-CONTROLLED VALVE - (DIRECT ACTING)**

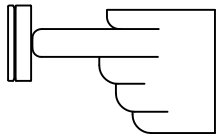
**CONDITION:**

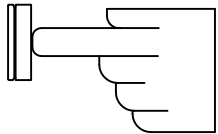
**SOLUTION:**

<p><b>NO WATER FLOW:</b></p>  	<ol style="list-style-type: none"> <li>1.1 Check water main supply – open.</li> <li>1.2 Inspect checkstops – open.</li> <li>1.3 Inspect checkstop strainer for debris – clean.</li> <li>1.4 Check 1/8” O.D. tubing and fittings for leaks.</li> <li>1.5 Check pushbutton air diaphragm for holes.</li> <li>1.6 Check servomotor diaphragm center hole for blockage.</li> </ol>
<p><b>WATER DRIPS / WILL NOT SHUT OFF:</b></p> 	<ol style="list-style-type: none"> <li>2.1 Check servomotor diaphragm offset hole for debris.</li> <li>2.2 Check servomotor seat for build-up or damage.</li> <li>2.3 Check servomotor seat o-ring for damage.</li> <li>2.4 Check servomotor plate and diaphragm for obstruction.</li> </ol>
<p><b>REDUCED WATER FLOW:</b></p>  	<ol style="list-style-type: none"> <li>3.1 Check water main supply for 20 psig minimum flow pressure.</li> <li>3.2 Check valve riser tubing for crimping.</li> <li>3.3 Inspect checkstop strainer for debris – clean.</li> <li>3.4 Check valve flow control for blockage – clean.</li> <li>3.5 Inspect bubbler for debris – clean.</li> </ol>
<p><b>PREMATURE WATER SHUTOFF:</b></p>  	<ol style="list-style-type: none"> <li>4.1 Check 1/8” O.D. tubing and fittings for leaks.</li> <li>4.2 Check pushbutton air diaphragm for holes.</li> </ol>

Refer to Air-Controlled Valve Maintenance Detail on drawing # 9940-203-001 for -FRA\_ Above Ground units and on drawing # 9940-204-001 for Stone & -FRU\_ Below Ground units to locate solutions above.

	<p>MURDOCK-SUPER SECUR P.O. Box 3527 Industry, CA 91744 15125 Proctor Ave Industry, CA 91746 Phone: (800) 591-9880 www.murdock-supersecur.com</p>	<p><b>FRU FREEZE RESISTANT FOUNTAIN VALVE MAINTENANCE INSTRUCTIONS</b></p>		
<p>TITLE <b>JANUARY 2006 TO PRESENT</b></p>		<p>MANUFACTURE DATE <b>10/20/05</b></p>	<p>DATE ISSUED <b>10/20/05</b></p>	<p>DRAWING NUMBER <b>9940-202-001</b></p>
		<p>DATE REVISED <b>03/15/16</b></p>		



**PUSH PAD / PUSH BUTTON BELOW GROUND FREEZE RESISTANT DRINKING FOUNTAINS  
NON-METERING AIR-CONTROLLED VALVE - (DIRECT ACTING)**

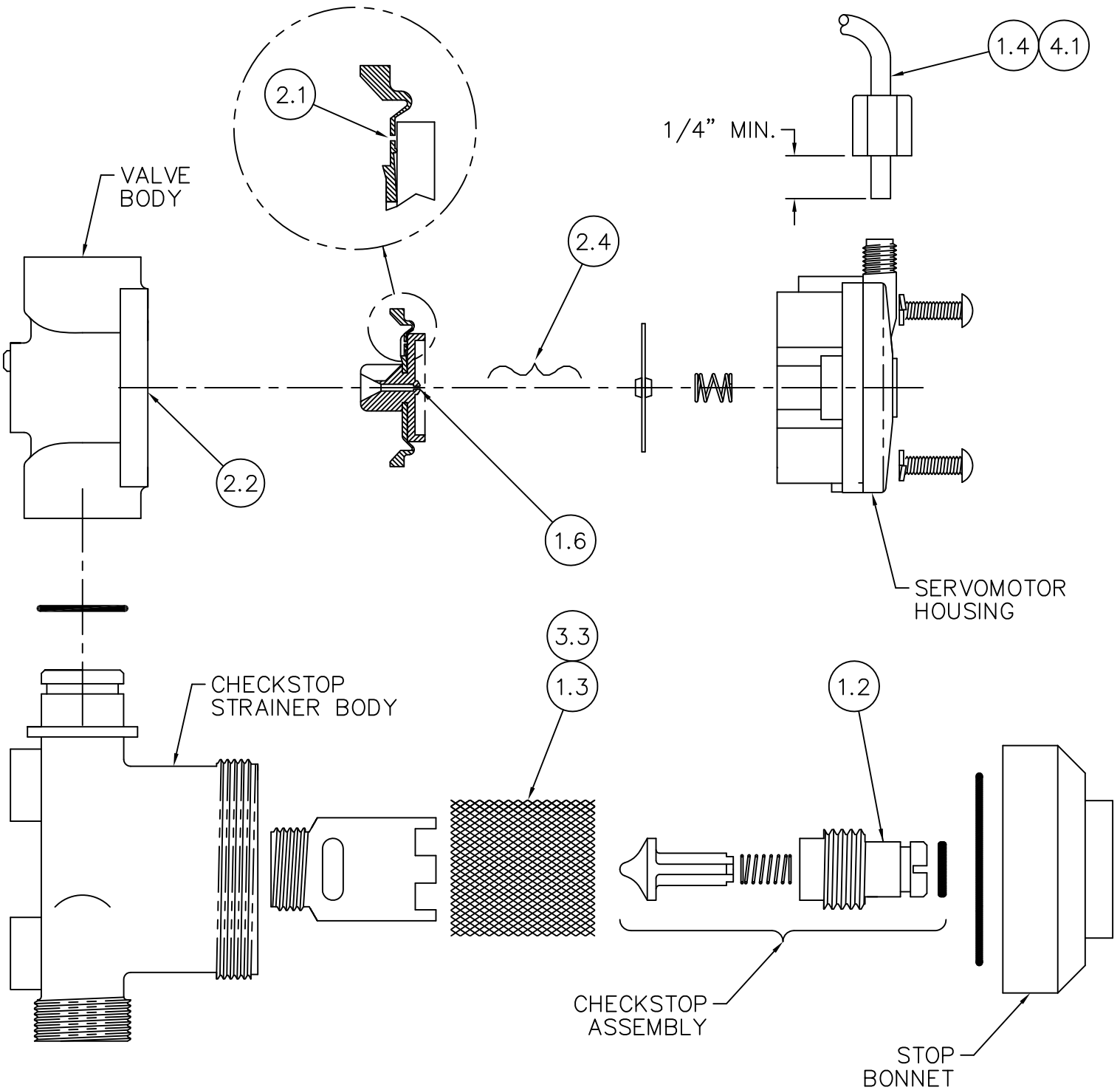

**CHECKSTOP STRAINER - SERVOMOTOR DETAIL**

Refer to drawing #9940-202-001 for Valve Maintenance Instructions numbered solutions detailed above.

<p>MURDOCK-SUPER SECUR P.O. Box 3527 Industry, CA 91744 15125 Proctor Ave Industry, CA 91746 Phone: (800) 591-9880 www.murdock-supersecur.com</p>	<p>TITLE <b>NON-METERING FRU AIR-CONTROLLED VALVE MAINTENANCE INSTRUCTIONS</b></p>		
	<p>MANUFACTURE DATE</p> <p><b>JANUARY 2006 TO PRESENT</b></p>	<p>DATE ISSUED</p> <p><b>12/07/05</b></p>	<p>DRAWING NUMBER</p> <p><b>9940-204-001</b></p>
		<p>DATE REVISED</p> <p><b>03/15/16</b></p>	