

## BF12R Bottle Filler Series

H<sub>2</sub>O TO GO!<sup>®</sup> RETROFIT DECK MOUNT  
SENSOR OPERATED BOTTLE FILLER

### STANDARD FEATURES

#### Bottle Filler

- ADA Compliant
- 100-Mesh Inlet Strainer
- 120VAC/9.0VDC Plug-In Transformer
- Hands-Free Sensor Operation
- 1 GPM Laminar Flow Nozzle
- 20 Second Maximum Run Time

#### Retrofit Basin

- Rear Sloped Basin w/ Hole
- Fits existing A171, A172, Water Cooler Series

### SUGGESTED SPECIFICATIONS

#### Bottle Filler BF12R

Bottle Filling unit shall include Sensor operated activation with a 20 second maximum run time. Housing construction will be 20 gage Stainless Steel with a satin finish and will also include components manufactured from Antimicrobial, impact resistant ABS. Bottle Filler shall provide approximately 1.0 GPM flow rate with a Laminar Flow Spout to minimize splashing. Optional -BCD (Bottle Counter Display) indicates the quantity of 16 oz disposable Plastic Bottles saved from a land fill. -BCD option displays the Water Filter status and includes LED Light to illuminate and brighten the Bottle Fill area when a bottle is detected.

#### Retrofit Basin

Basin shall be constructed from 304 stainless steel and have an integral drain.



### MODEL:

(Must Specify)

- BF12R Sensor Operated Bottle Filler w/ Retrofit Basin

### OPTIONS

(additional costs may be incurred)

- BCD Bottle Counter Display

Complies with the following standards:



Federal Public Law 111-380 (No Lead)



NSF/ANSI/CAN 61

[Product Warranty](#)

**⚠ WARNING: Cancer and Reproductive Harm - [www.P65Warnings.ca.gov](http://www.P65Warnings.ca.gov)**

**MURDOCK MFG.** • 15125 Proctor Avenue • City of Industry, CA 91746 USA  
Phone 800-453-7465 or 626-333-2543 • [www.murdockmfg.com](http://www.murdockmfg.com)

Member of  
**MORRIS GROUP**  
INTERNATIONAL

**BF12R Bottle Filler Series**

H<sub>2</sub>O TO GO!<sup>®</sup> DECK MOUNT SENSOR OPERATED BOTTLE FILLER

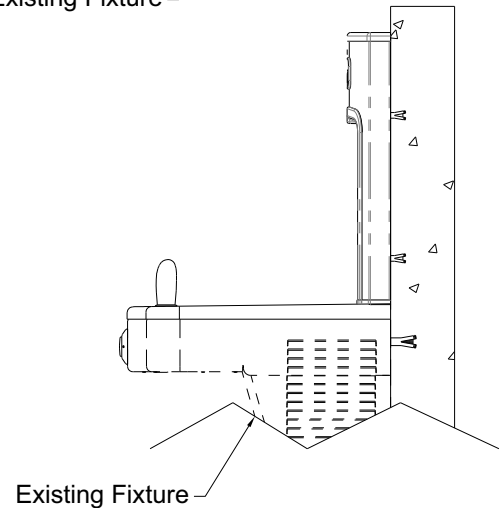
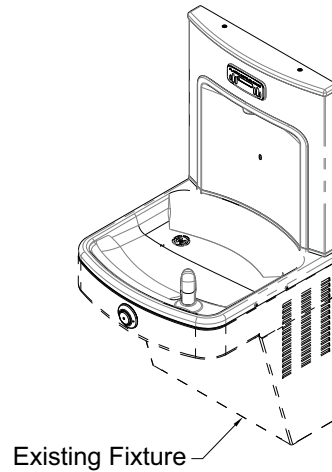
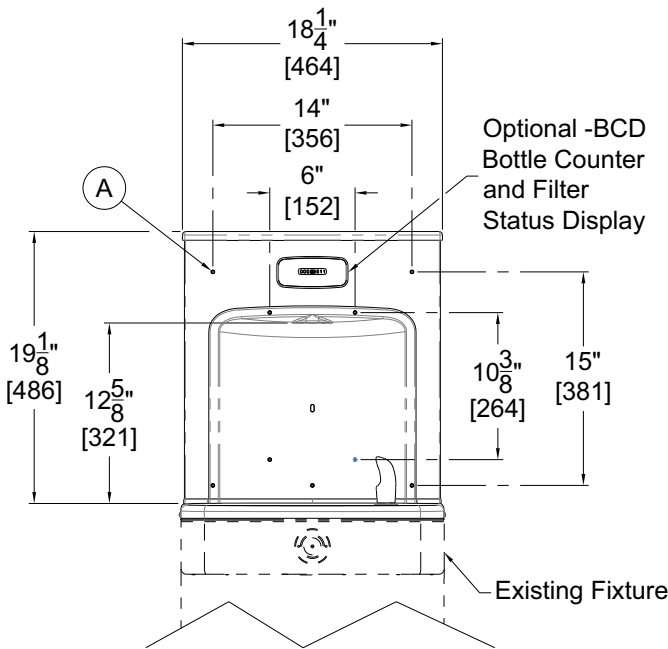
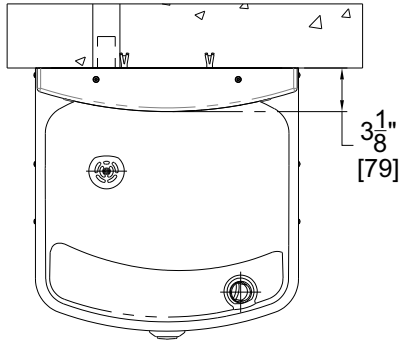

**General Note:**

1. All dimensions are in inches [MM]

- A. Ø1/4" Holes, 10 Places for Anchoring Hardware, provided by others

<b>SELECTION SUMMARY &amp; APPROVAL FOR MANUFACTURING</b>	Model Number & Options _____	Quantity _____	<i>All dimensions are subject to manufactures tolerance of plus or minus 1/4" nominal and subject to change without notice. Murdock<sup>®</sup> assumes no responsibility for use of void or superseded data. Dimensions may change with the addition of optional accessories. Murdock<sup>®</sup> Mfg., Member of Morris Group International<sup>®</sup>. Please visit <a href="http://www.murdockmfg.com">www.murdockmfg.com</a> for most current specifications.</i>
	Company _____		
	Contact _____	Title _____	
	Signature (Approval for Manufacturing) _____	Date _____	