

BF12 Bottle Filler Series

H₂O TO GO![®] SENSOR OPERATED BOTTLE FILLER

STANDARD FEATURES

- ADA Compliant
- 100-Mesh Inlet Strainer
- 120VAC/9V DC Plug-In Transformer
- Hands-Free Sensor Operation
- 1 GPM Laminar Flow Nozzle
- 20 Second Maximum Run Time
- Fits existing Murdock[®] A171, A172, Water Cooler Series
- May be used with certain competitor models (Contact Factory for more information)

SUGGESTED SPECIFICATIONS

Bottle Filler unit may be used on certain existing Murdock[®] Manufacturing units or models which include Bottle Filler. Existing Drinking Fountain may require alteration for connection to Bottle Filler. Unit to include Sensor operated activation with a 20 second maximum run time. Housing construction to be heavy gauge stainless steel with a #4 satin finish and to include components manufactured from antimicrobial, impact resistant ABS. Bottle Filler shall provide approximately 1.0 GPM flow rate with a Laminar Flow Spout to minimize splashing. Optional -BCD (Bottle Counter Display) indicates the quantity of 16 oz disposable Plastic Bottles saved from a land fill. -BCD option displays the Water Filter Status and includes LED Light to illuminate and brighten the Bottle Fill area when a Bottle is detected. Optional -WF1 Water Filter meets NSF 42 and 53 requirements and reduces lead content in the drinking water by 99%. Unit shall be certified to Public Law 111-380 (NO-LEAD) and NSF/ANSI/CAN 61.



Model BF12-BCD Shown

"INDOOR USE ONLY"

MODEL:

(Must Specify)

- BF12 Sensor Operated Bottle Filler
- BF12-BAT Sensor Operated Bottle Filler, Battery Powered

OPTIONS

(additional costs may be incurred)

- BCD Bottle Counter Display ¹
- WF1 1500-gallon capacity Water Filter (Note: Shipped loose for Assembly to Water Cooler)

Options Notes:

¹ Requires Electrical, Not Available on -BAT Battery Powered models.

Complies with the following standards:



Federal Public Law 111-380 (No Lead)



NSF/ANSI/CAN 61

[Product Warranty](#)

⚠ WARNING: Cancer and Reproductive Harm - www.P65Warnings.ca.gov

BF12 Bottle Filler Series

H₂O TO GO![®] SENSOR OPERATED
BOTTLE FILLER

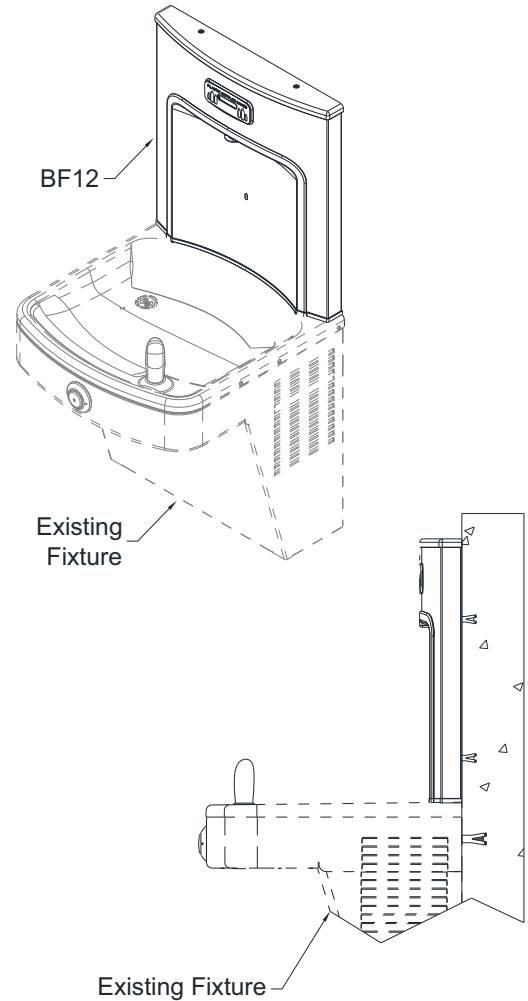
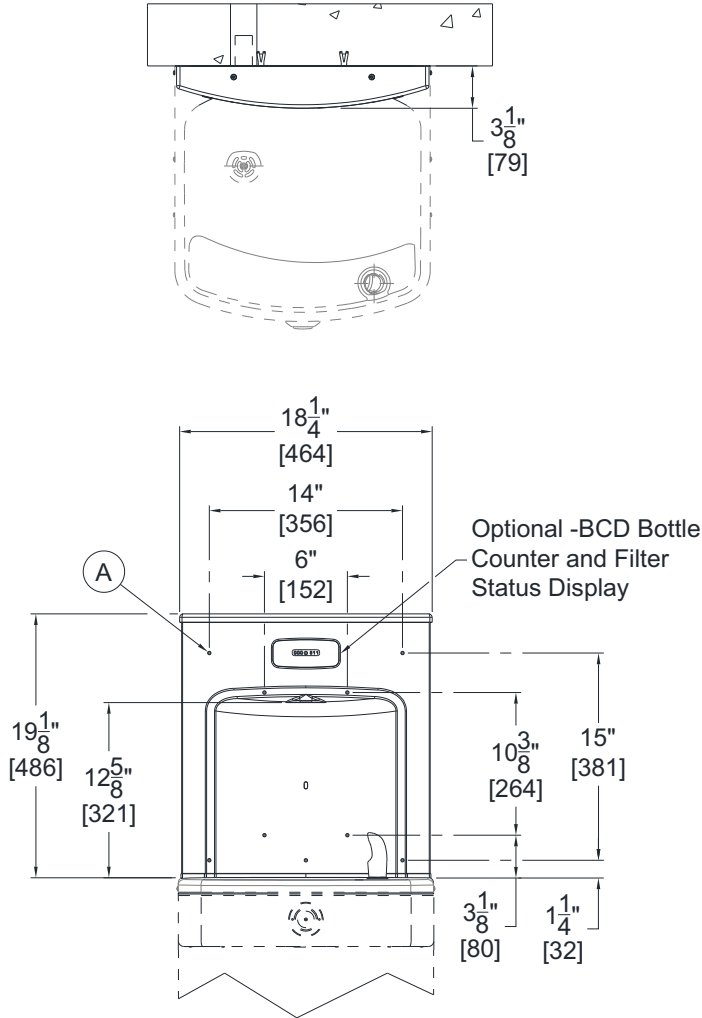

General Note:

1. All dimensions are in inches [MM]

- A. Ø1/4" Holes, 10 Places for Anchoring Hardware, provided by others

**SELECTION SUMMARY
& APPROVAL FOR
MANUFACTURING**

Model Number & Options _____	Quantity _____
Company _____	
Contact _____	Title _____
Signature (Approval for Manufacturing) _____	Date _____

All dimensions are subject to manufactures tolerance of plus or minus 1/4" nominal and subject to change without notice. Murdock[®] assumes no responsibility for use of void or superseded data. Dimensions may change with the addition of optional accessories. Murdock[®] Mfg., Member of Morris Group International[®]. Please visit www.murdockmfg.com for most current specifications.