

## BF11 Bottle Filler Series

H<sub>2</sub>O TO GO!<sup>®</sup> PUSHBUTTON OPERATED  
BOTTLE FILLER

### STANDARD FEATURES

- ADA Compliant
- 100-Mesh Inlet Strainer
- Pushbutton Operation
- 1 GPM Laminar Flow Nozzle
- Fits A171-UG, A172-UG Series Fountains and Coolers
- May be used with certain competitor models  
(Contact Factory for more information)

### SUGGESTED SPECIFICATIONS

Bottle Filling unit shall include Pushbutton operated activation. Existing Drinking Fountain may require alteration for connection to Bottle Filler. Housing construction will be 20 gage Stainless Steel with a satin finish and will also include components manufactured from Antimicrobial, impact resistant ABS. Bottle Filler shall provide approximately 1.0 GPM flow rate with a Laminar Flow Spout to minimize splashing. Unit shall be certified to Public Law 111-380 (NO-LEAD) and NSF/ANSI/CAN 61. Optional WF3000 PFAS Water Filter shall have 3000 gallon capacity with 3rd Party Certification for Lead, Bacteria, Chlorine, Microplastics, and NSF/ANSI 53 for Cyst and total PFAS reduction.



**"INDOOR USE ONLY"**

### MODEL:

(Must Specify)

- BF11 Pushbutton Operated Bottle Filler

### ACCESSORIES:

(Additional costs may apply. Accessory items are packaged separately.)

- WF3000 3000-Gallon PFAS Water Filter<sup>1</sup>  
NSF/ANSI, PFAS, Lead, Bacteria, Chlorine, Microplastics

### NOTES:

1- Refer to Supplemental Submittal Sheet for details.

Complies with the following standards:



Federal Public Law 111-380 (No Lead)



NSF/ANSI/CAN 61

[3000 Gallon PFAS Filter Certifications](#)

[Product Warranty](#)

WARNING: Cancer and Reproductive Harm - [www.P65Warnings.ca.gov](http://www.P65Warnings.ca.gov)

MURDOCK MFG. • 15125 Proctor Avenue • City of Industry, CA 91746 USA  
Phone 800-453-7465 or 626-333-2543 • [www.murdockmfg.com](http://www.murdockmfg.com)

Member of  
MORRIS GROUP  
INTERNATIONAL

**BF11 Bottle Filler Series**

H<sub>2</sub>O TO GO!<sup>®</sup> PUSHBUTTON  
OPERATED BOTTLE FILLER

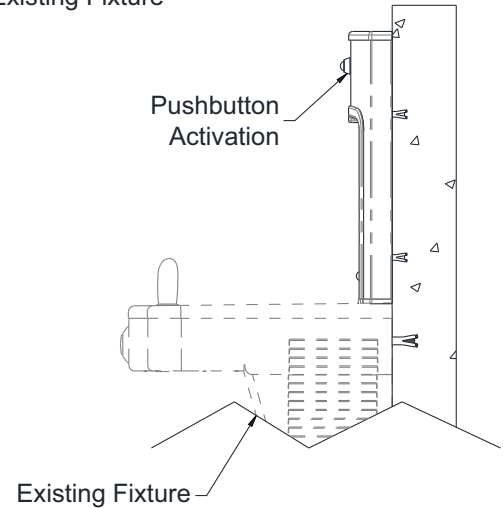
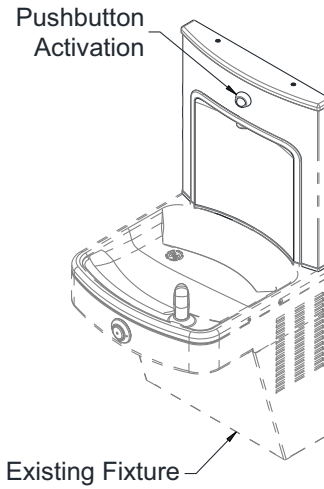
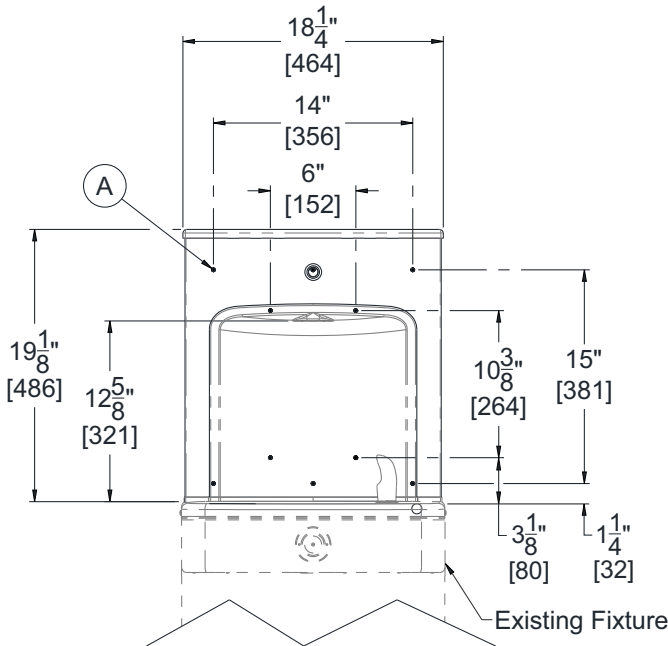
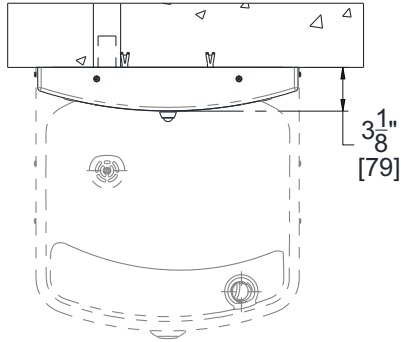

General Note:

1. All dimensions are in inches [MM]

- A. Ø1/4" Holes, 10 Places for Anchoring Hardware, provided by others

<b>SELECTION SUMMARY &amp; APPROVAL FOR MANUFACTURING</b>	Model Number & Options _____	Quantity _____	<p><i>All dimensions are subject to manufactures tolerance of plus or minus 1/4" nominal and subject to change without notice. Murdock<sup>®</sup> assumes no responsibility for use of void or superseded data. Dimensions may change with the addition of optional accessories. Murdock<sup>®</sup> Mfg., Member of Morris Group International<sup>®</sup>. Please visit <a href="http://www.murdockmfg.com">www.murdockmfg.com</a> for most current specifications.</i></p>
	Company _____		
	Contact _____	Title _____	
	Signature (Approval for Manufacturing) _____	Date _____	