



DRINKING FOUNTAIN

A132-BF3 Series

BARRIER FREE, BI-LEVEL, WALL MOUNTED DRINKING FOUNTAIN WITH SEMI-RECESSED PUSHBUTTON OPERATED BOTTLE FILLER AND 32" TRIM PANEL

STANDARD FEATURES

- Both Child or Adult ADA Compliant (when properly installed)
- 18 gage, 304 Stainless Steel Bowl
- Polished Lead-Free Stainless Steel, anti-rotation non-squirt Bubbler or Flexible Low Flow Bubbler
- 100-Mesh Inlet Strainer
- Mounting frame
- 32" Wide Trim Panel
- 1 GPM. Fill Rate (Bottle Filler)
- Laminar Flow Water Supply (Bottle Filler)

SUGGESTED SPECIFICATIONS

Model A132400S-BF3 is a Wall Mounted, Bi-Level Drinking Fountain and Bottle Filler Combination made from 18 gage, 304 Stainless Steel with a brushed finish. Fountain shall be activated by self-closing, Frontal Push Pads, by using less than 5 pounds of force, which activates internally mounted Valves with Adjustable Stream Regulators controlling the water flow. Bottle Filler shall be activated by pneumatically operated Hemispherical Pushbutton. Bubblers shall be polished Stainless Steel with non-squirt features and operate on a water pressure range of 20-105 PSIG. Unit shall have uniquely designed, Two-Piece Contoured Bowls with P-traps integral to the unit. Fountain is certified to ANSI A117.1, NSF/ANSI 61, Section 9, Public Law 111-380 (NO-LEAD), and CHSC 116875. Fixture meets ADA, ADA Standing Person, and ADA Child requirements when mounted appropriately.



MODEL:

(Must Specify)

FLEXIBLE BUBBLER (LOW FLOW)

- A132200F-BF3 Bronze Finish
- A132300F-BF3 Gold Finish (High Polish)
- A132400F-BF3 Satin stainless Finish

LEAD-FREE STAINLESS STEEL BUBBLER

- A132200S-BF3 Bronze Finish
- A132300S-BF3 Gold Finish (High Polish)
- A132400S-BF3 Satin stainless Finish (Shown)

OPTIONS

(additional costs may be incurred)

- AP3 Access Panel for a Dual Fountain
- HP High Polished Stainless Steel
- RBL Reverse Bi-Level (Bottle Filler Opposite)
- SK4 Skirt Kit, Stainless Steel, for upper unit
- WF1 1500-gallon capacity, NSF 42+53, 1 micron Lead Reduction Filter
- A9100080-A 8 GPH Remote Water Chiller (Recommended to be with 10 Feet of Fixture)

Complies with the following standards:



Member of U.S. Green Building Council



Recyclable Product



Water Conserving Product

⚠ WARNING: Cancer and Reproductive Harm - www.P65Warnings.ca.gov
 ⚠ ADVERTENCIA: Cáncer y daño reproductivo - www.P65Warnings.ca.gov

MURDOCK MFG. • 15125 Proctor Avenue • City of Industry, CA 91746 USA
 Phone 800-453-7465 or 626-333-2543 • Fax 626-855-4860 • www.murdockmfg.com

Member of MORRIS GROUP INTERNATIONAL



DRINKING FOUNTAIN

A132-BF3 Series

BARRIER FREE, BI-LEVEL, WALL MOUNTED DRINKING FOUNTAIN WITH SEMI-RECESSED PUSHBUTTON OPERATED BOTTLE FILLER AND 32" TRIM PANEL

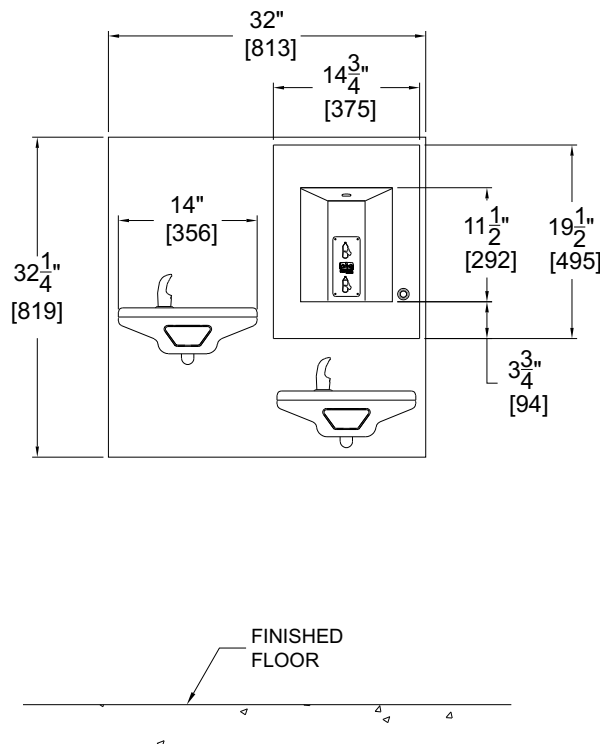
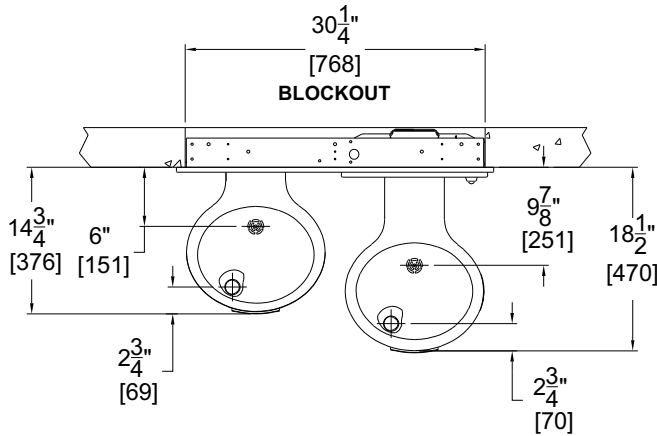

General Notes:
 1. All dimensions are in inches [MM].
 *2. Dimensions shown are for recommended adult height. Adjust vertical dimensions as necessary to comply with Federal, State, & Local Codes.

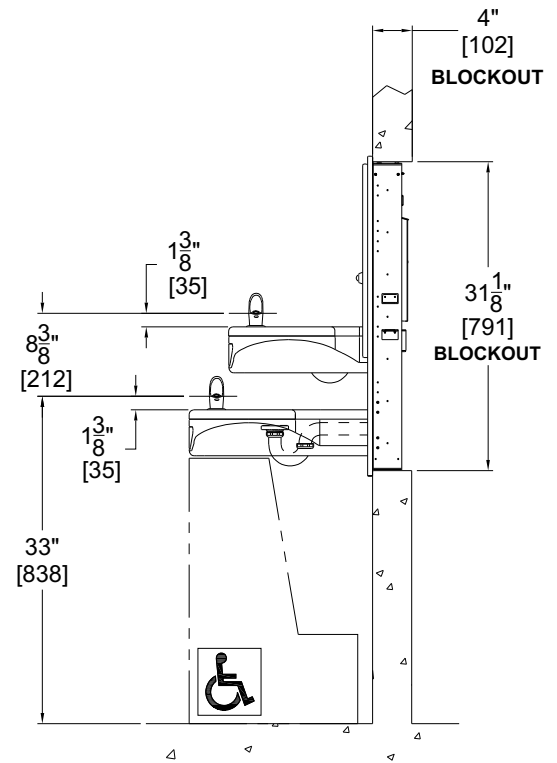

Murdock Mfg.™ warrants that its products are free from defects in material or workmanship under normal use and service for a period of one year from date of shipment. Murdock's liability under this warranty shall be discharged solely by replacement or repair of defective material, provided Murdock™ is notified in writing within one year from date of shipment, F.O.B. Industry, California.

SELECTION SUMMARY & APPROVAL FOR MANUFACTURING	Model Number & Options _____	Quantity _____	All dimensions are subject to manufactures tolerance of plus or minus 1/2" nominal and subject to change without notice. Murdock assumes no responsibility for use of void or superseded data. Dimensions may change with the addition of optional accessories. Murdock Mfg.™, Member of Morris Group International™. Please visit www.murdockmfg.com for most current specifications.
	Company _____		
	Contact _____	Title _____	
	Signature (Approval for Manufacturing) _____	Date _____	

MURDOCK MFG. • 15125 Proctor Avenue • City of Industry, CA 91746 USA
 Phone 800-453-7465 or 626-333-2543 • Fax 626-855-4860 • www.murdockmfg.com

Member of MORRIS GROUP INTERNATIONAL